

# CZAR | WELD TOOLS

---

Concrete, masonry, and asphalt tools proudly made in the USA for almost half a century.

## CONCRETE TOOLS

Concrete placers	1
Bull floats / Bull float brackets	2
Hand floats / Hand mags	3
Handle adapters / Power trowel hangers	4
Chute tool / Form funnel / Wall topper float	5
Concrete slab cutter / Curb-it tool	6
Concrete tampers / Highway straightedges	7
Footing keyway groover / One-man screed	8
Heavy-duty hand screeds	9
Ski-boards / Kneeboards	10
Concrete shovels / Wall shovels	11
Wall hoes / Concrete joint groovers	12
Slab cutters / Hand groovers	13
Walking groovers	14
Hand edgers	15
Walking edgers / Curb & gutter hand tools	16
Walking curb & gutter tools	17

## MASONRY TOOLS

Mortar hods / Brick hods / Mortar hoes	18
--	----

## ASPHALT TOOLS

Asphalt lutes / Serrated asphalt lutes	19
--	----

---

**CREDIT:** \$100 minimum order. Unless otherwise instructed, please contact us for a credit application before your initial order. Alternatively, your initial order may be paid for in advance by credit card, check, or ACH payment.

---

**PRICES:** Prices subject to change without notice. Please contact us regarding special pricing for large volume orders.

---

**TERMS:** Unless otherwise informed, payment is due NET 30 from date of invoice. Past due invoices are charged 1% interest penalty per month (12% per annum) on the unpaid balance after 30 days.

---

**DELIVERY:** Most orders are shipped within 48 hours. Some orders, such as large or custom orders, may take an additional day or two. If delivery is critical, please notify us of your requirements and we will accommodate you if at all possible.

---

**FREIGHT:** All prices are FOB House Springs, MO. Truck-only items are marked in the catalog with an asterisk.

---

**GUARANTEE:** Czar Weld Tools, Inc. guarantees its tools against any defective material or workmanship. Any such product will, at our option, be replaced or repaired free of charge if returned to us with shipping charges prepaid. Our liability under all warranties, expressed or implied, shall be limited to the replacement or repair of defective products.

**THE ORIGINAL "SMOOTH MOVER" CONCRETE PLACER**



Simply the best concrete placer on the market. Made from high-strength tempered aluminum alloy, the Smooth Mover is strong enough to pull mesh with the corners of the blade, so you don't need a hook! Includes 60" x 1-3/8" hardwood handle.

**Works great for moving sand, chat, and asphalt, too.**

SIZE	PART NO.
20" x 4" Blade	CWT-120
30" x 4" Blade	CWT-130
48" x 4" Blade	CWT-148

**SNAP-LOCK SMOOTH MOVER**

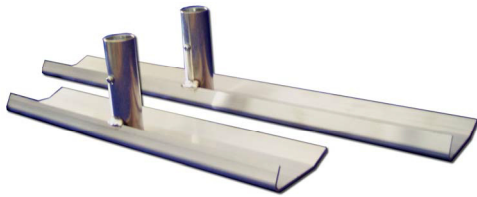

Our top-quality "Smooth Mover" placer head with a snap-lock socket. Accepts all standard 1-3/4" and 1-3/8" snap-lock handles (not included).

SIZE	PART NO.
20" x 4" Blade	CWT-120-SL
30" x 4" Blade	CWT-130-SL

**SMOOTH MOVER EXTREME\***



Want a practically indestructible concrete placer? Check out our new all-aluminum Smooth Mover. Features a full 6' heavy-duty ribbed aluminum handle welded in place for added strength.

**\* Must be shipped via truck.**

SIZE	PART NO.
20" x 4" Blade	CWT-120-A
30" x 4" Blade	CWT-130-A

**THE CZAR-WELD BULL FLOAT**



Made from FORMED high-strength tempered aluminum alloy, not extrusion, resulting in a longer-wearing surface that resists warping better than an extruded float. Features 6-hole universal mounting plate so that you can attach any bracket.

**Flared edges reduce lap marks.**

**Size: 48" x 8"**

SIZE	PART NO.
No Bracket Included	CWT-248
Includes Rock-'Em Adjustable Bracket	CWT-248-16R

**STANDARD BULL FLOAT**

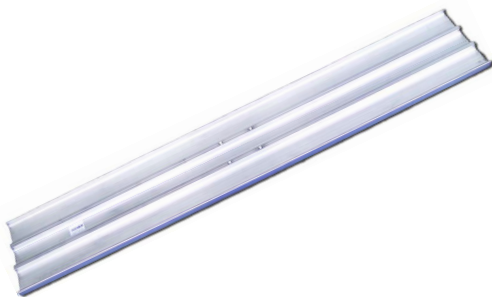

Made from extruded high-strength tempered aluminum alloy, this bull float features a "broken-in" surface. Four tapped holes allow attachment of any standard bracket (not included).

SIZE	PART NO.
8" x 42"	CWT-49-ABF-42
8" x 48"	CWT-49-ABF-48

**ROCK-'EM BULL FLOAT BRACKET**



Adjust the angle of your bull float simply by turning the handle. The Rock-'Em fits all standard 2-hole and 4-hole bull floats and fresnos, and accepts all standard 1-3/4" and 1-3/8" snap-lock handles. Eliminates back strain and makes low ceiling work possible. Made from rustproof aluminum. Hardware included.

SIZE	PART NO.
-	CWT-16R

CONCRETE TOOLS

16" CAST MAG FLOAT



Die-cast magnesium. Size is 3-1/2" x 16". Features a comfortable, replaceable wooden handle. Working surface is broken in and corners are rounded.

SIZE	PART NO.
3-1/2" x 16"	CWT-52HM-16

16" HAND MAG



Made from top-quality extruded magnesium. Size is 3-1/8" x 16". Working surface is broken in at the factory. Features a comfortable, replaceable wooden handle.

SIZE	PART NO.
3-1/8" x 16"	CWT-46HM-16

CANVAS-RESIN HAND FLOATS



Our laminated canvas-resin floats are 3/8"-thick and long-wearing. Bottom surface is roughed and ready to use. Brings concrete back to life!

SIZE	PART NO.
3-1/2" x 12"	CWT-47RHM-12
3-1/2" x 14"	CWT-47RHM-14
3-1/2" x 16"	CWT-47RHM-16
3-1/2" x 18"	CWT-47RHM-18
3-1/2" x 20"	CWT-47RHM-20

ALLOY HAND MAG



Made from our special long-wearing alloy. Broken-in surface from the factory. Features a comfortable wooden handle.

SIZE	PART NO.
3-1/8" x 12"	CWT-45AHM-12
3-1/8" x 14"	CWT-45AHM-14
3-1/8" x 16"	CWT-45AHM-16
3-1/8" x 18"	CWT-45AHM-18
3-1/8" x 20"	CWT-45AHM-20

**THREADED HANDLE ADAPTER**



This handy adapter converts snap-lock handles to threaded handles. Allows standard threaded brackets to accept 1-3/4" or 1-3/8" snap-lock handles.

SIZE	PART NO.
-	CWT-17HA

**ALUMINUM BROOM ADAPTER**



Rustproof aluminum adapter bolts to any broom, replacing worn-out wooden threads.

**Get more life from that old broom!**

SIZE	PART NO.
-	CWT-29ABA

**CONCRETE CHUTE HANGER**



Hanger grabs onto floor joists using the weight of the concrete chute. Comes with chain to attach your chute. Pour basement slabs quicker!

**Includes 6 feet of chain with grab hook.**

SIZE	PART NO.
1000 lb cap.	CWT-28ACH

**POWER TROWEL HANGER**

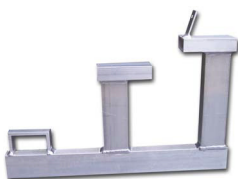

Hanger grabs onto floor joists using the weight of the trowel itself. Hang your power trowel in place before pouring your basement slab, making it easy to start your finishing when and where you want. 500-pound capacity.

**Handy nailing tab for placement.**

SIZE	PART NO.
500 lb cap.	CWT-28APTH

CONCRETE TOOLS

THE CZAR-WELD CHUTE TOOL



Provide better flow control, eliminate spillage, and clean up faster with the Czar-Weld Chute Tool. The tough 6061-T6 tempered aluminum head is 12" x 8". The replaceable handle is 1-3/8" x 60" hardwood.

**Fits most ready-mix chutes.**

SIZE	PART NO.
-	CWT-9-CT

FORM FUNNEL



Put our Form Funnel under your chute exit and ensure the concrete goes into the form, not on it. Made from high-strength tempered aluminum alloy with replaceable handles. Works with forms 7" wide and up.

SIZE	PART NO.
16" x 16"	CWT-51FF

WALL TOPPER FLOATS



Use our unique floats to slick up foundation wall tops with ease. The Wall Topper will allow you to float along the wall instead of across it. Made from long-wearing 6061-T6 aluminum.

FOR WALL SIZE	PART NO.
6" - 10"	CWT-50WTF-10
8"	CWT-50WT-8
10"	CWT-50WT-10

**CONCRETE SLAB CUTTER\***

Our Concrete Slab Cutter features a full 2" x 4" tempered aluminum alloy blade. It is ideal for all concrete projects where improved flatness is required or desired. This cutter is lightweight enough for easy cross-cutting and re-straightening of fresh concrete surfaces. For final re-straightening of concrete surfaces, our ALL-WELDED WATER-TIGHT blade can be weighted with an additional 34 lb when filled with water. Includes Rock-'Em bracket and (3) six-foot snap-lock handles.

**\* Must be shipped via truck.**

The diagram shows a long, narrow aluminum blade with a triangular support structure. Callouts point to various features: a teflon bushing on a handle, a water fill plug on the blade, a universal mounting bracket, and the all-welded construction of the blade.

SIZE	PART NO.
10 ft Blade	CWT-2510-CSC
12 ft Blade	CWT-2512-CSC

**THE CURB-IT TOOL\***

Made from 1" x 2" aluminum tubing with welded end caps. Used for screeding and shaping concrete, this tool has two conveniently placed 1-3/8" x 6" wooden handles.

**\* Must be shipped via truck.**

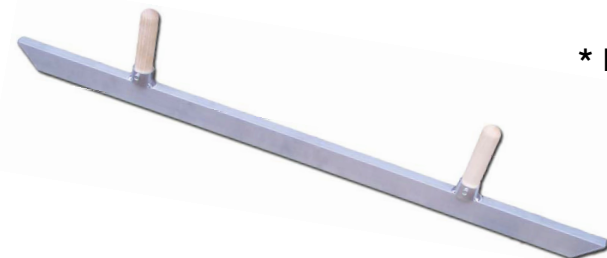

SIZE	PART NO.
48"	CWT-33-CIT-48
72"	CWT-33-CIT-72
96"	CWT-33-CIT-96
120"	CWT-33-CIT-120

**JITTERBUG CONCRETE TAMPERS\***



Our steel jitterbug features a flattened expanded metal mesh to push aggregate down just right. Our all-welded and double-reinforced construction guarantees that this tamper will stay flatter and last longer.

**\* Must be shipped via truck.**

SIZE	PART NO.
8" x 42"	CWT-37-SJB-42
8" x 48"	CWT-37-SJB-48

**HIGHWAY STRAIGHTEDGES\***

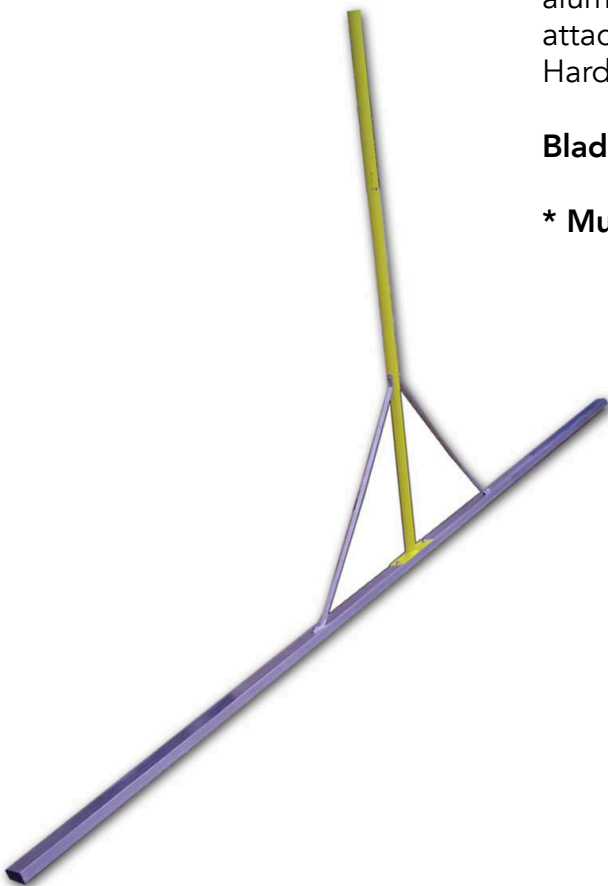

Czar Weld’s Highway Straightedges are perfect for checking flatness on large slabs. Available in steel or aluminum, our Straightedge blades are 1" x 2" and attach to a bolt-on rugged powder-coated steel handle. Hardware Kit includes outriggers and all fasteners.

**Blades, handles, hardware kits purchased separately.**

**\* Must be shipped via truck.**

PART	PART NO.
12 ft Handle	CWT-38SHS-12H
16 ft Handle	CWT-38SHS-16H
Hardware and Outrigger Kit	CWT-38SHS-OR
10 ft Blade – Steel	CWT-38SHSB-10
12 ft Blade – Steel	CWT-38SHSB-12
16 ft Blade – Steel	CWT-38SHSB-16
8 ft Blade – Aluminum	CWT-38AHSB-08
10 ft Blade – Aluminum	CWT-38AHSB-10
12 ft Blade – Aluminum	CWT-38AHSB-12
16 ft Blade – Aluminum	CWT-38AHSB-16



**FOOTING KEYWAY GROOVER**

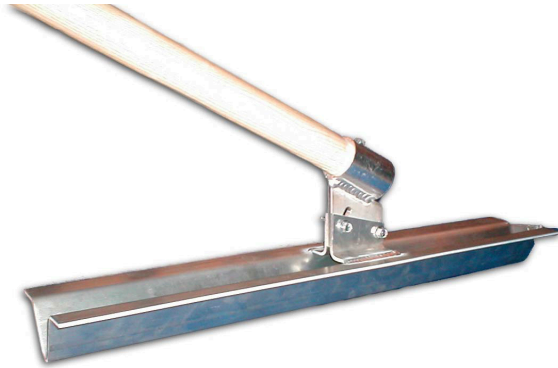

Our Keyway Groover will save you a lot of time and back strain when pouring footings. The tough 6061-T6 tempered aluminum head is 24" long by 4-1/2" wide and cuts a 2" x 2" groove. The fully-adjustable hardwood handle is 1-3/8" x 60".

SIZE	PART NO.
-	CWT-8 FKG

**THE ONE MAN SCREED\***

Made from 1" x 2" aluminum tubing with WELDED end caps. This versatile tool allows the user to screed with the narrow face and then float with the wide face! Includes 72" x 1-3/8" hardwood handle.

**Custom sizes available.**

**\* Sizes over 60" must be shipped via truck.**



SIZE	PART NO.
36"	CWT-32-OMS-36
42"	CWT-32-OMS-42
48"	CWT-32-OMS-48
60"	CWT-32-OMS-60
72"	CWT-32-OMS-72
96"	CWT-32-OMS-96

**HEAVY-DUTY HAND SCREEDS\***

Made from our toughest alloy, these hand screeds all feature a FULL 1/8" wall thickness for superior strength and stiffness. Won't dent like thin-walled ribbed screeds. Welded-on-end caps ensure your screed can't fill with concrete.

**\* Must be shipped via truck.**



CROSS-SECTION	LENGTH	PART NO.
1" x 4"	4'	CWT-30HS-1X4-04
1" x 4"	6'	CWT-30HS-1X4-06
1" x 4"	8'	CWT-30HS-1X4-08
1" x 4"	10'	CWT-30HS-1X4-10
1" x 4"	12'	CWT-30HS-1X4-12
1" x 4"	14'	CWT-30HS-1X4-14
1" x 4"	16'	CWT-30HS-1X4-16
1-1/2" x 3-1/2"	4'	CWT-26HHS-04
1-1/2" x 3-1/2"	6'	CWT-26HHS-06
1-1/2" x 3-1/2"	8'	CWT-26HHS-08
1-1/2" x 3-1/2"	10'	CWT-26HHS-10
1-1/2" x 3-1/2"	12'	CWT-26HHS-12
1-1/2" x 3-1/2"	14'	CWT-26HHS-14
1-1/2" x 3-1/2"	16'	CWT-26HHS-16
1-1/2" x 3-1/2"	18'	CWT-26HHS-18
1-1/2" x 3-1/2"	20'	CWT-26HHS-20
2" x 4"	4'	CWT-30HS-2X4-04
2" x 4"	6'	CWT-30HS-2X4-06
2" x 4"	8'	CWT-30HS-2X4-08
2" x 4"	10'	CWT-30HS-2X4-10
2" x 4"	12'	CWT-30HS-2X4-12
2" x 4"	14'	CWT-30HS-2X4-14
2" x 4"	16'	CWT-30HS-2X4-16
2" x 4"	18'	CWT-30HS-2X4-18
2" x 4"	20'	CWT-30HS-2X4-20
2" x 5"	16'	CWT-30HS-2X5-16
2" x 5"	18'	CWT-30HS-2X5-19
2" x 5"	20'	CWT-30HS-2X5-20
2" x 5"	24'	CWT-30HS-2X5-24

**STAINLESS STEEL SKI-BOARDS**

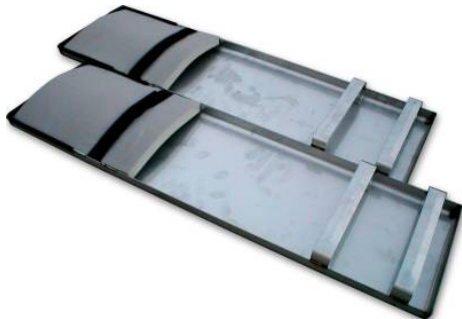

Made from the best-quality stainless steel with comfortable closed-cell foam pads, these ski-boards will not rust; pads won't absorb water. Toe brackets allow for easy movement.

**Replacement pads and straps available.**

SIZE	PART NO.
8" x 28-1/2"	CWT-14-800SS
6-1/2" x 28-1/2"	CWT-14-650SS

**ALUMINUM SKI-BOARDS**



Made from lightweight and durable aluminum alloy with comfortable closed-cell foam pads, these ski-boards will not rust; pads won't absorb water. Toe brackets allow for easy movement while kneeling or walking.

**Replacement pads and straps available.**

SIZE	PART NO.
8" x 28-1/2"	CWT-15-800A
6-1/2" x 28-1/2"	CWT-15-650A

**ALUMINUM KNEEBOARDS**



This will be the last pair of kneeboards you will ever need. Made from durable 1/8" thick aluminum alloy with comfortable closed-cell foam pads, these kneeboards will not rust, and pads won't absorb water.

SIZE	PART NO.
12" x 22"	CWT-3KB

CONCRETE TOOLS

**ALUMINUM WALL SHOVELS**

Made from 6061-T6 tempered aluminum, these light but strong shovels are excellent for moving concrete in poured walls. Four different REPLACEABLE handle styles are available: Aluminum Straight, Aluminum T-Grip, Hardwood Straight, and Hardwood D-Grip.



Hardwood Straight and D-Grip

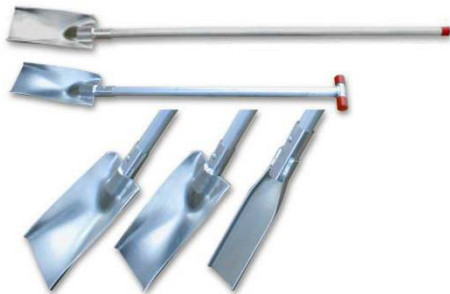

Aluminum Straight and T-Grip

SHOVEL WIDTH	HANDLE TYPE	OVERALL LENGTH	PART NO.
3-1/2"	Hardwood D-Grip	54"	CWT-12350-DG
3-1/2"	Hardwood Straight	69"	CWT-12350-SHH
3-1/2"	Aluminum T-Grip	48"	CWT-13350-ATH
3-1/2"	Aluminum Straight	69"	CWT-13350-SAH
5-3/4"	Hardwood D-Grip	52"	CWT-12575-DG
5-3/4"	Hardwood Straight	69"	CWT-12575-SHH
5-3/4"	Aluminum T-Grip	46"	CWT-13575-ATH
5-3/4"	Aluminum Straight	69"	CWT-13575-SAH
7"	Hardwood D-Grip	52"	CWT-12700-DG
7"	Hardwood Straight	69"	CWT-12700-SHH
7"	Aluminum T-Grip	46"	CWT-13700-ATH
7"	Aluminum Straight	69"	CWT-13700-SAH

**ALUMINUM CONCRETE SHOVELS**

Made from 6061-T6 tempered aluminum, these light but strong shovels will help you handle mortar and concrete while minimizing your effort. Models 737 & 745 feature extra pitch and a deep-pan head to help move more material. Models 1840 & 1848 have a shallow head for use in leveling, puddling, and screed work. Shovel head is 11" x 9-1/4". Long and short handle lengths available. Features a D-Grip handle.



HEAD TYPE	OVERALL LENGTH	PART NO.
Deep	37"	CWT-737
Deep	48"	CWT-745
Shallow	41"	CWT-1840
Shallow	51"	CWT-1848

CONCRETE TOOLS

ALUMINUM WALL HOES

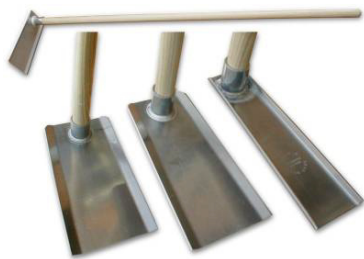

Hardwood handle

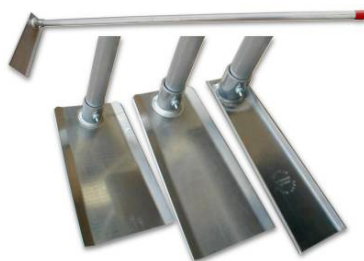

Aluminum handle

Made from 6061-T6 tempered aluminum, these light but strong hoes are excellent for moving concrete in poured walls. Features a 1-3/8" x 60" replaceable straight handle in either aluminum or hardwood.

BLADE WIDTH	HANDLE TYPE	PART NO.
3-1/2"	Hardwood	CWT-10350
5-3/4"	Hardwood	CWT-10575
7"	Hardwood	CWT-10700
3-1/2"	Aluminum	CWT-11350-AH
5-3/4"	Aluminum	CWT-11575-AH
7"	Aluminum	CWT-11700-AH

CONTROL JOINT GROOVERS

Cutting control joints is a snap with our new streamlined groovers. Made from durable aluminum, these groovers feature a machined cutting nose on both ends as well as a sight tab to ensure a straight joint. Use our 12" single-ended hand-held model for cleaning up joint ends. Makes 1" deep joints. Attach our snap-lock handle socket (sold separately) or use your own favorite adjustable bracket.



Handle sockets

LENGTH	TYPE	PART NO.
1 FT	Hand	CWT-54JG-12
2 FT	Walking	CWT-54JG-24
3 FT	Walking	CWT-54JG-36
4 FT	Walking	CWT-54JG-48
5 FT	Walking	CWT-54JG-60

TYPE	PART NO.
Threaded	CWT-58-TH
Snap-Lock	CWT-58-SLH

**SLAB CUTTERS**



Made from high-strength alloy aluminum, our hard-wearing slab cutters are available in two different blade depths to ensure 25% cut on concrete slabs up to 8" thick. Edges are flared up to prevent finish marring. Bi-directional. **Replacement blades available.**

BLADE DEPTH	PART NO.
1-1/8"	CWT-22-SC-118
2"	CWT-22-SC-200

**ALUMINUM HAND GROOVERS**



Made from 1/8" thick 6061-T6 hard-rolled tempered aluminum, our hand-held groovers are great for smaller jobs and detail work. Both sizes are 8" long, replaceable blade is 1-1/8" deep with a 3/8" radius. The blade is cut flush with the back edge of the float, allowing full-depth grooving against a bulk head or form line.

**Replacement blades available.**

FLOAT WIDTH	PART NO.
12"	CWT-20-HHG
4"	CWT-21-HHG

**STAINLESS HAND GROOVERS**



Made from heavy-duty stainless steel, these groovers are great for smaller jobs and detail work. Float base is 10" x 10" with 3/4"-high sides for running down straight edges such as our Hand Screeds. Two different widths and two different radii available.

**Replacement blades available.**

FLOAT WIDTH	RADIUS	PART NO.
4"	3/8"	CWT-27-SHG04-038
4"	1/2"	CWT-27-SHG04-050
10"	3/8"	CWT-27-SHG10-038
10"	1/2"	CWT-27-SHG10-050

**ALUMINUM WALKING GROOVERS**

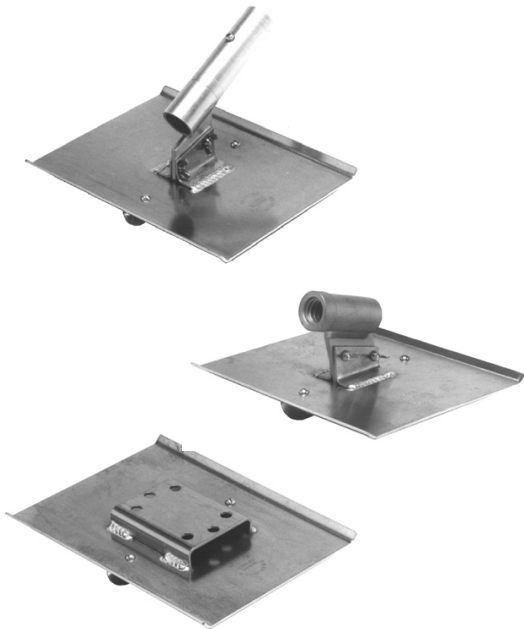

Made from 1/8" -thick 6061-T6 hard-rolled tempered aluminum, our walking groovers are great for long-reach jobs. Float base is 9" x 12", blade is 9" long, 1-1/8" deep with a 3/8" radius.

- Snap-Lock version fits both 1-3/8" and 1-3/4" handles.
- Threaded version fits all standard threaded handles.
- Universal version has a 6-hole pattern to accept any standard bracket.

TYPE	PART NO.
Snap-Lock	CWT-20-SLH
Threaded	CWT-20-TH
Universal	CWT-20-UMB

**STAINLESS WALKING GROOVERS**

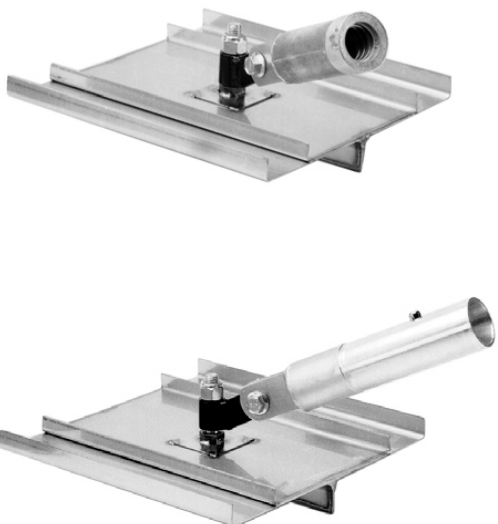

Made from heavy-duty stainless steel, these walking groovers are great for long-reach jobs. Float base is 10" x 10" with 3/4" high sides for running down straight edges such as our Hand Screeds. Features a multiple-angle swivel head to allow any handle positioning. Blade is 1-1/8" deep with a 3/8" or 1/2" radius. Snap-Lock version fits both 1-3/8" and 1-3/4" handles. Threaded version fits all standard threaded handles.

TYPE	RADIUS	PART NO.
Snap-Lock	3/8"	CWT-27-SWGSL-038
Snap-Lock	1/2"	CWT-27 -WGSL-050
Threaded	3/8"	CWT-27-SWGTH-038
Threaded	1/2"	CWT-27-SWGTH-050

**CLEVELAND-STYLE SIDEWALK EDGERS**

Made from 12 ga steel or 16 ga stainless steel, these hand-held edgers are popular in the Midwest. All edgers feature our comfortable float-type handle.



SIZE	RADIUS	MATERIAL	PART NO.
8-3/4" x 3-1/2"	1/2"	12 ga Steel	CWT-56-SE-06
8-3/4" x 3-1/2"	1/2"	16 ga Stainless	CWT-56-SE-06-S
8-1/4" x 2"	1/2"	12 ga Steel	CWT-56-SE-07
8-1/4" x 2"	1/2"	16 ga Stainless	CWT-56-SE-07-S
8-3/4" x 2-1/2"	1/2"	12 ga Steel	CWT-56-SE-08
8-3/4" x 2-1/2"	1/2"	16 ga Stainless	CWT-56-SE-08-S

**STAINLESS HAND EDGERS**

Made from heavy-duty stainless steel, our hand-held edgers are available in five popular radii. All edgers are 9" x 3-1/2" and feature our comfortable float handle. Choose our Mitered version for close quarter edging on inside angles that are hard to finish.



CORNER STYLE	RADIUS	PART NO.
Squared	1/4"	CWT-27-SHE-04-025
Squared	3/8"	CWT-27-SHE-04-038
Squared	1/2"	CWT-27-SHE-04-050
Squared	3/4"	CWT-27-SHE-04-075
Squared	1"	CWT-27-SHE-04-100
Mitered	1/4"	CWT-27-MHE-35-025
Mitered	3/8"	CWT-27-MHE-35-038
Mitered	1/2"	CWT-27-MHE-35-050
Mitered	3/4"	CWT-27-MHE-35-075
Mitered	1"	CWT-27-MHE-35-100

**10" STAINLESS HAND EDGERS**

Made from heavy-duty stainless steel, our heavy-duty hand-held edgers are available in five popular radii. Turned-up blade edges prevent gouging and allow easy two-way edging. All edgers are 10" x 10" and feature our comfortable float handle.



RADIUS	PART NO.
1/4"	CWT-27-SHE-10-025
3/8"	CWT-27-SHE-10-038
1/2"	CWT-27-SHE-10-050
3/4"	CWT-27-SHE-10-075
1"	CWT-27-SHE-10-100



**STAINLESS WALKING EDGERS**

Made from heavy-duty stainless steel, our walking edgers are available in five popular radii. Base is 10" x 10" with turned-up plate edges to prevent gouging. Features a multiple-angle swivel head to allow any handle positioning. Snap-Lock version fits both 1-3/8" and 1-3/4" handles (not included). Threaded version fits standard threaded handles (not included). Hardwood version INCLUDES our 60" hardwood handle.

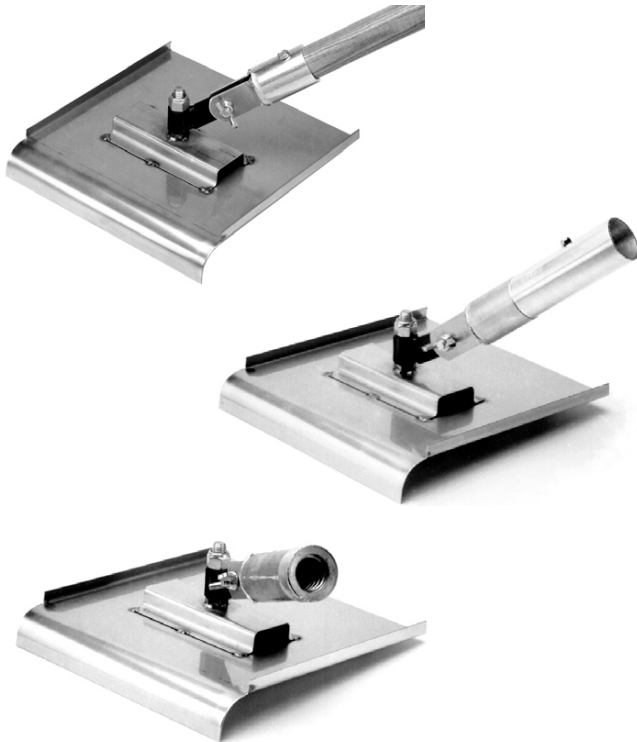

HANDLE TYPE	RADIUS	PART NO.
Hardwood	1/4"	CWT-27 SWEWH-025
Hardwood	3/8"	CWT-27 SWEWH-038
Hardwood	1/2"	CWT-27 SWEWH-050
Hardwood	3/4"	CWT-27 SWEWH-075
Hardwood	1"	CWT-27 SWEWH-100
Snap-Lock	1/4"	CWT-27 SWESL-025
Snap-Lock	3/8"	CWT-27 SWESL-038
Snap-Lock	1/2"	CWT-27 SWESL-050
Snap-Lock	3/4"	CWT-27 SWESL-075
Snap-Lock	1"	CWT-27 SWESL-100
Threaded	1/4"	CWT-27 SWETH-025
Threaded	3/8"	CWT-27 SWETH-038
Threaded	1/2"	CWT-27 SWETH-050
Threaded	3/4"	CWT-27 SWETH-075
Threaded	1"	CWT-27 SWETH-100

**CURB & GUTTER HAND TOOLS**

Made from hard-wearing but flexible 9" x 9" stainless steel, our curb & gutter tools have just the right feel. Mitered corners help in close quarters. All-welded construction, rivet-free. Available in 7 different radii.



RADIUS	CURB TOOL PART NO.	GUTTER TOOL PART NO.
1/4"	CWT-24-OHH-025	CWT-24-IHH-025
3/8"	CWT-24-OHH-038	CWT-24-IHH-038
1/2"	CWT-24-OHH-050	CWT-24-IHH-050
3/4"	CWT-24-OHH-075	CWT-24-IHH-075
1"	CWT-24-OHH-100	CWT-24-IHH-100
1-1/2"	CWT-24-OHH-150	CWT-24-IHH-150
2"	CWT-24-OHH-200	CWT-24-IHH-200

**WALKING CURB & GUTTER TOOLS**

Made from hard-wearing but flexible 9" x 9" stainless steel, these curb & gutter tools have just the right feel. Available in 7 different radii. Features a multiple-angle swivel head to allow any handle positioning. Snap-Lock version fits both 1-3/8" and 1-3/4" handles (not included). Threaded version fits all standard threaded handles (not included). Hardwood version INCLUDES our 1-3/8" x 60" hardwood handle.

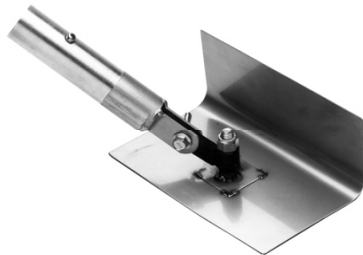

HANDLE TYPE	RADIUS	CURB TOOL PART NO.	GUTTER TOOL PART NO.
Hardwood	1/4"	CWT-24-OVWH-025	CWT-24-IVWH-025
Hardwood	3/8"	CWT-24-OVWH-038	CWT-24-IVWH-038
Hardwood	1/2"	CWT-24-OVWH-050	CWT-24-IVWH-050
Hardwood	3/4"	CWT-24-OVWH-075	CWT-24-IVWH-075
Hardwood	1"	CWT-24-OVWH-100	CWT-24-IVWH-100
Hardwood	1-1/2"	CWT-24-OVWH-150	CWT-24-IVWH-150
Hardwood	2"	CWT-24-OVWH-200	CWT-24-IVWH-200
Snap-Lock	1/4"	CWT-24-OVSL-025	CWT-24-IVSL-025
Snap-Lock	3/8"	CWT-24-OVSL-038	CWT-24-IVSL-038
Snap-Lock	1/2"	CWT-24-OVSL-050	CWT-24-IVSL-050
Snap-Lock	3/4"	CWT-24-OVSL-075	CWT-24-IVSL-075
Snap-Lock	1"	CWT-24-OVSL-100	CWT-24-IVSL-100
Snap-Lock	1-1/2"	CWT-24-OVSL-150	CWT-24-IVSL-150
Snap-Lock	2"	CWT-24-OVSL-200	CWT-24-IVSL-200
Threaded	1/4"	CWT-24-OVT-025	CWT-24-IVT-025
Threaded	3/8"	CWT-24-OVT-038	CWT-24-IVT-038
Threaded	1/2"	CWT-24-OVT-050	CWT-24-IVT-050
Threaded	3/4"	CWT-24-OVT-075	CWT-24-IVT-075
Threaded	1"	CWT-24-OVT-100	CWT-24-IVT-100
Threaded	1-1/2"	CWT-24-OVT-150	CWT-24-IVT-150
Threaded	2"	CWT-24-OVT-200	CWT-24-IVT-200

**ALUMINUM MORTAR HOD**



There is no comparison between our hods and the flimsy hods you may find elsewhere! Climb ladders more safely by using our heavy-duty Aluminum Mortar Hod. The durable and rustproof 6061-T6 tempered aluminum body is 24" x 12" x 1/8" thick and cleans up easily with water. The replaceable handle is 1-3/8" x 60" hardwood.

**Holds up to 110 lbs of mortar.**

CAPACITY	PART NO.
110 lbs	CWT-4-MH

**ALUMINUM BRICK HODS**



Climb ladders more safely by using our Aluminum Brick Hods. The durable and rustproof 6061-T6 tempered aluminum body is 24" long and cleans up easily with water. The replaceable handle is 1-3/8" x 60" hardwood.

**Holds up to 20 bricks.**

SIZE	PART NO.
20 new bricks	CWT-5-BH
14 king bricks	CWT-5-KINGBH

**ALUMINUM MORTAR HOE**



Mix mortar faster and easier with our well-balanced Aluminum Mortar Hoe. The tough 6061-T6 tempered aluminum head is 9" x 7" with a wide oval hole for better mixing. The replaceable handle is 1-3/8" x 60" hardwood. Weighs only 3 lbs.

SIZE	PART NO.
-	CWT-6-MHO

ASPHALT TOOLS

**ASPHALT LUTES**

Made from high-strength alloy aluminum, these asphalt lutes feature a 30" blade and are a standard in the industry. Choose from either a 1-3/8" x 72" stout hardwood handle or our practically indestructible heavy-wall aluminum handle. Special sizes available.



HANDLE TYPE	PART NO.
Hardwood	CWT-31-ALWH
Aluminum	CWT-31-ALAH

**SERRATED ASPHALT LUTES**

Made from high-strength alloy aluminum in a special T-shape design, these asphalt lutes come in several blade lengths and are a standard in the industry. Choose either a 1-3/8" x 72" stout hardwood handle or our practically indestructible heavy-wall aluminum handle.



HANDLE TYPE	BLADE LENGTH	PART NO.
Hardwood	24"	CWT-34-SALWH-24
Hardwood	32"	CWT-34-SALWH-32
Hardwood	36"	CWT-34-SALWH-36
Hardwood	42"	CWT-34-SALWH-42
Aluminum	24"	CWT-34-SALAH-24
Aluminum	32"	CWT-34-SALAH-32
Aluminum	36"	CWT-34-SALAH-36
Aluminum	42"	CWT-34-SALAH-42